

# TRUNNION BALL VALVE / 1900

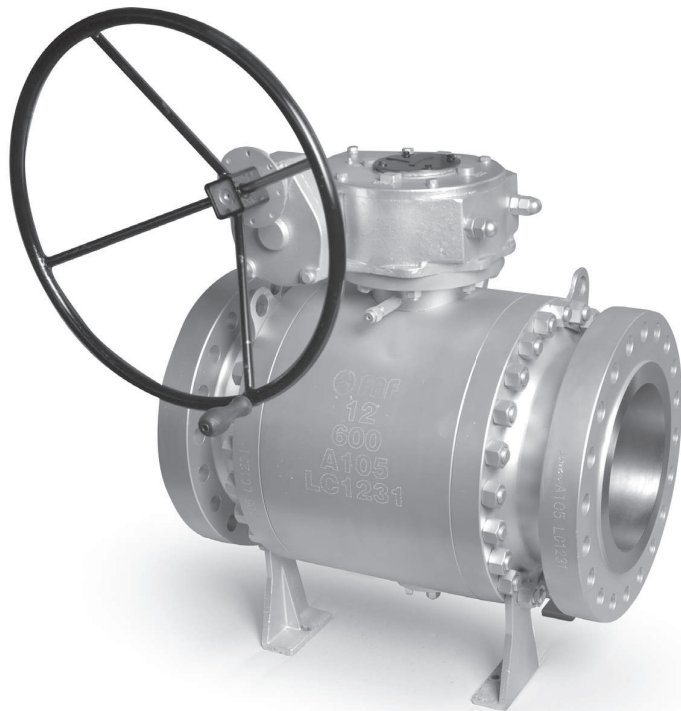

**CLASS 150/300/600**  
DN50 → DN600

#### PRODUCTION STANDARDS

DESIGN	API 6D / ASME B16.34
END CONNECTION	ASME B16.5
FACE TO FACE	API 6D / ASME B16.10
PRESSURE TEST	API 6D / API 598
FIRE TEST	API 607 / ISO 10497
MARKING	API 6D

## FEATURES

- FAF 1900, trunnion type ball valve is operating by a ball having a hole with the same size as the flow section, through the help of the stem, rotating quarter turn (90 degree) between teflon seats fixed to the body with moving springs where the ball to be parallel or perpendicular to the flow axis
- Designed and manufactured according to ANSI standard
- Can be installed bidirectional
- The well accordance of teflon material with various flow types and its resistance to higher temperatures enables it to be used in wide range of applications
- Its ball can be manufactured in steel or stainless steel, body can be cast steel or forged steel
- Designed as fire safe, tested according to standards by exposing to fire conditions
- Through its antistatic feature, the arc possibility between valve parts are prevented
- In order to release the high pressure that may occur inside its body space, automatic pressure release valves are placed on the body
- Oil injection plugs are available for valve maintenance and ease of usage
- It is appropriate to be used in fully open or fully closed position
- In fully open position, since there is no reduction in flow section, the head loss is nearly zero
- Suitable to install actuator and gearbox

## APPLICATIONS

Hot Water, Cold Water, Steam, Chemicals, Lubricants, Natural Gas

## TEMPERATURE

-30, +200 °C

## TECHNICAL DRAWING

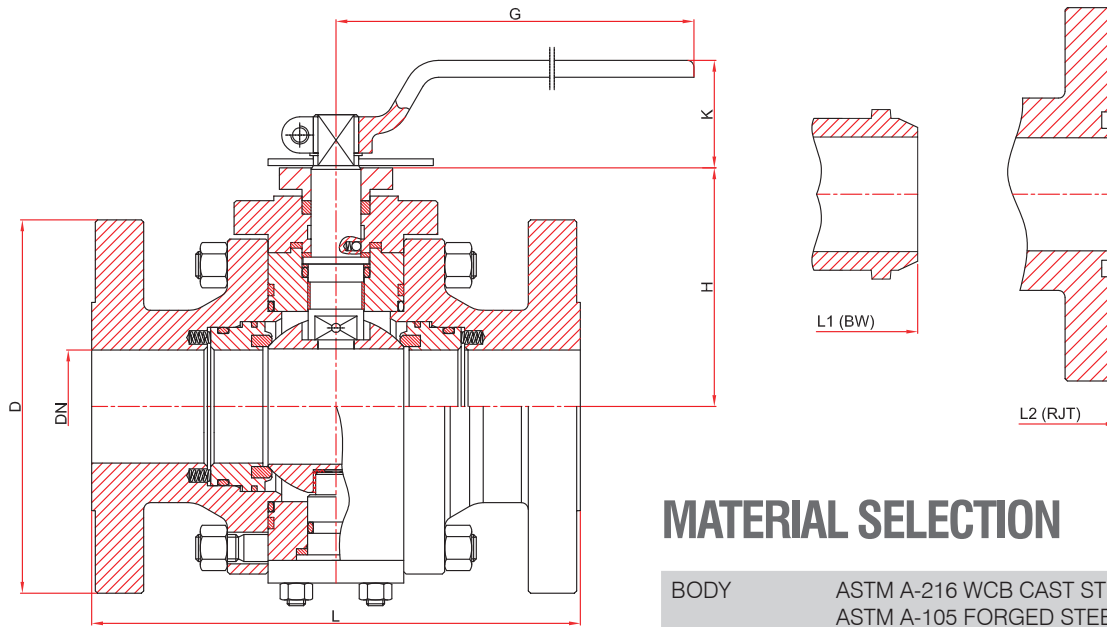

## MATERIAL SELECTION

**BODY** ASTM A-216 WCB CAST STEEL  
ASTM A-105 FORGED STEEL

**BALL** ASTM A-105 FORGED STEEL+ENP  
1.4301 - AISI 304 STAINLESS STEEL  
1.4401 - AISI 316 STAINLESS STEEL

**STEM** ASTM A-105 FORGED STEEL+ENP  
1.4301 - AISI 304 STAINLESS STEEL  
1.4401 - AISI 316 STAINLESS STEEL

**SEALING** TEFLON (PTFE)  
NYLON

**COATING** INDUSTRIAL EPOXY

DN	NPS	CLASS 150				CLASS 300				CLASS 600			
		D	L - RF	L1 - BW	L2 - RTJ	D	L - RF	L1 - BW	L2 - RTJ	D	L - RF	L1 - BW	L2 - RTJ
50	2	150	178	216	191	165	216	216	232	165	292	292	295
65	2 1/2	180	191	241	203	190	241	241	257	190	330	330	333
80	3	190	203	283	216	210	283	283	298	210	356	356	359
100	4	230	229	305	241	255	305	305	321	275	432	432	435
150	6	280	394	457	406	320	403	403	419	355	559	559	562
200	8	345	457	521	470	380	502	502	517	420	660	660	664
250	10	405	533	559	546	445	568	568	584	510	787	787	791
300	12	485	610	635	622	520	648	648	664	560	838	838	841
350	14	535	686	762	699	585	762	762	778	605	889	889	892
400	16	595	762	838	775	650	838	838	854	685	991	991	994
450	18	635	864	914	876	710	914	914	930	745	1092	1092	1095
500	20	700	914	991	927	775	991	991	1010	815	1194	1194	1200
600	24	815	1067	1143	1080	915	1143	1143	1165	940	1397	1397	1407