

# GATE VALVE / 6300

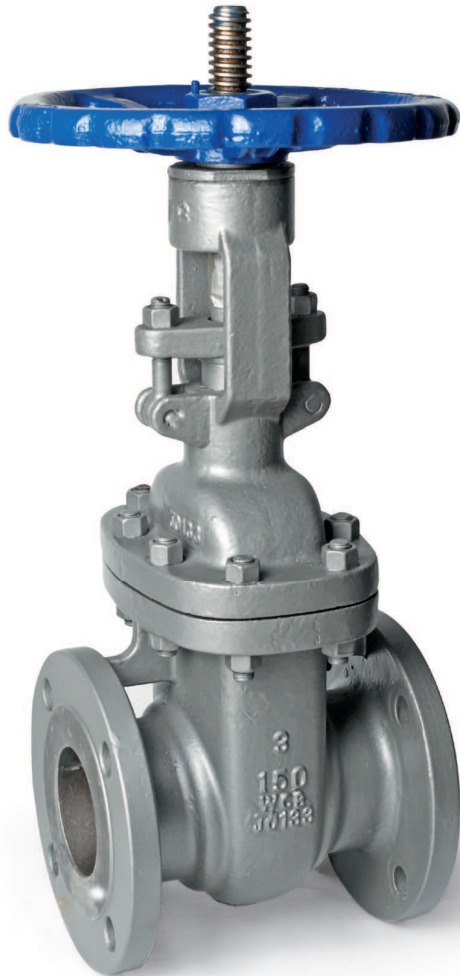

**CLASS 150/300/600**  
DN50 → DN600

#### PRODUCTION STANDARDS

DESIGN	API 6D / ASME B16.34
END CONNECTION	ASME B16.5
FACE TO FACE	API 6D / ASME B16.10
PRESSURE TEST	API 6D / API 598
MARKING	API 6D

## FEATURES

- FAF6300 Gate Valve is operating by the steel wedge moving perpendicular to the flow axis through a worm machined stem multi turned
- Sealing is maintained by the stainless steel welding filled wedge seats on the wedge seat inside the body
- Designed and manufactured according to ANSI standard
- In each time the valve is opened, the flow on the line cleans the sealing surface, prevents from dirt and deposits
- Can be installed bidirectional
- It has cast steel body, stainless steel stem
- Suitable to install actuator and gearbox
- Very low head loss rating. Can be operated with lower torque ratings, no maintenance needed

## APPLICATIONS

Hot Water, Cold Water, Steam, Chemicals, Lubricants, Natural Gas, Oil&Gas, HVAC

## TEMPERATURE

-30, +200 °C

# TECHNICAL DRAWING

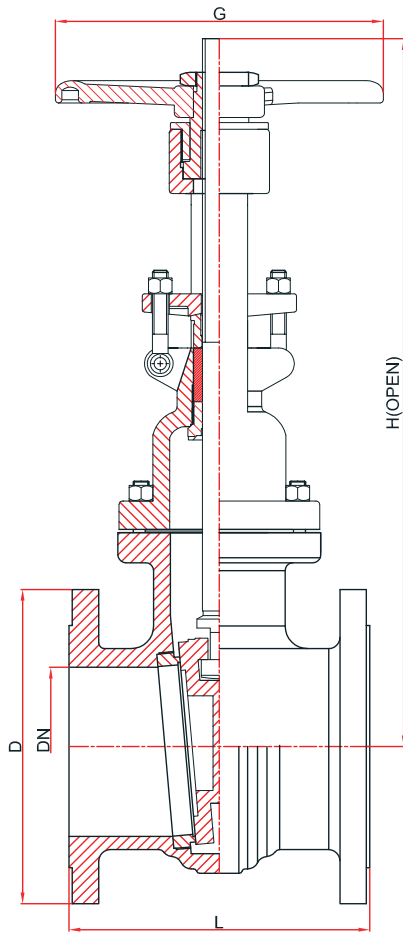

## MATERIAL SELECTION

BODY	ASTM A-216 WCB CAST STEEL
GATE	ASTM A-216 WCB CAST STEEL
STEM	1.4021 - AISI 420 STAINLESS STEEL 1.4301 - AISI 304 STAINLESS STEEL 1.4401 - AISI 316 STAINLESS STEEL
SEALING	MS 58 - BRASS 1.4021 - AISI 420 STAINLESS STEEL 1.4301 - AISI 304 STAINLESS STEEL 1.4401 - AISI 316 STAINLESS STEEL
COATING	INDUSTRIAL EPOXY

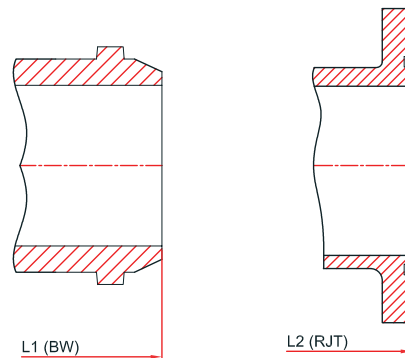

DN	NPS	CLASS 150				CLASS 300				CLASS 600			
		Ø mm	INC	D	L - RF	L1 - BW	L2 - RTJ	D	L - RF	L1 - BW	L2 - RTJ	D	L - RF
50	2	150	178	216	191	165	216	216	232	165	292	292	295
65	2 1/2	180	191	241	203	190	241	241	257	190	330	330	333
80	3	190	203	283	216	210	283	283	298	210	356	356	359
100	4	230	229	305	241	255	305	305	321	275	432	432	435
150	6	280	267	403	279	320	403	403	419	355	559	559	562
200	8	345	292	419	305	380	419	419	435	420	660	660	664
250	10	405	330	457	343	445	457	457	473	510	787	787	791
300	12	485	356	502	368	520	502	502	518	560	838	838	841
350	14	535	381	572	394	585	762	762	778	605	889	889	892
400	16	595	406	610	419	650	838	838	854	685	991	991	994
450	18	635	432	660	445	710	914	914	930	745	1092	1092	1095
500	20	700	457	711	470	775	991	991	1010	815	1194	1194	1200
600	24	815	508	813	521	915	1143	1143	1165	940	1397	1397	1407